

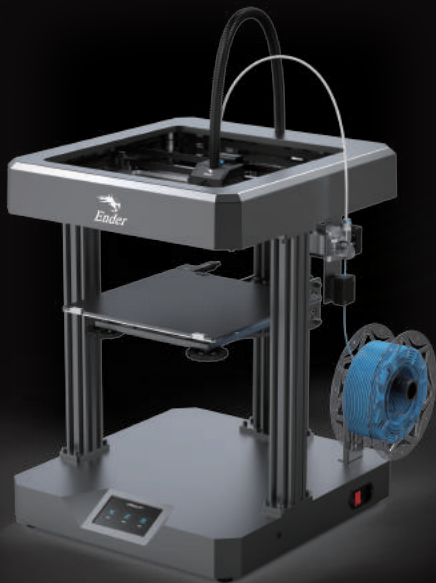

创造现实，成就梦想
Create reality, achieve dreams

Ender-7

Ender-7



3D Printer User Manual

3D打印机用户使用手册

V1.1

Dear Consumers,

Thank you for choosing our products. For the best experience, please read the instructions before operating the printer. Our teams will always be ready to render you the best services. Please contact us via the phone number or e-mail address provided at the end when you encounter any problem with the printer. For a better experience in using our product, you can also learn how to use the printer in the following ways:

View the accompanied instructions and videos in the storage card.

Visit our official website www.creality.com to find relevant software/hardware information, contact details and operation and maintenance instructions.

尊敬的用户：

感谢您选择创想三维的产品。为了您使用方便，请您在使用之前仔细阅读本说明书，并严格按照说明书的指示进行操作。

创想三维团队时刻准备为您提供优质的服务。在使用过程中无论遇到什么问题，请按照说明书结尾所提供的电话、邮箱与我们进行联系。为了您能够更好地体验我们的产品，您还可以从以下方式获取设备操作知识：

随机使用说明：您可以在存储卡内找到相关使用说明及视频。

您还可以登陆创想三维官网(www.cxsw3d.com)寻找相关软硬件、联系方式、设备操作、设备保养等信息。

Firmware Upgrade

Please login the official website <https://www.creality.com/download>, switch the language and select the relevant printer and model and download the required firmware, you can use it after the installation is finished.

固件升级

请您登录官网<https://www.cxsw3d.com>，点击首页→服务支持→下载所需固件，安装完成后即可使用。

- 1 Do not use the printer any way other than described herein in order to avoid personal injury or property damage.
- 2 Do not place the printer near any heat source or flammable or explosive objects. We suggest placing it in a well-ventilated, low-dust environment.
- 3 Do not expose the printer to violent vibration or any unstable environment, as this may cause poor print quality.
- 4 Before using experimental or exotic filaments, we suggest using standard filaments such as ABS or PLA to calibrate and test the machine.
- 5 Do not use any other power cable except the one supplied. Always use a grounded three-prong power outlet.
- 6 Do not touch the nozzle or printing surface during operation as they may be hot. Keep hands away from machine while in use to avoid burns or personal injury.
- 7 Do not wear gloves or loose clothing when operating the printer. Such cloths may become tangled in the printers moving parts leading to burns, possible bodily injury, or printer damage.
- 8 When cleaning debris from the printer hotend, always use the provided tools. Do not touch the nozzle directly when heated. This can cause personal injury.
- 9 Clean the printer frequently. Always turn the power off when cleaning, and wipe with a dry cloth to remove dust, adhered printing plastics or any other material off the frame, guide rails, or wheels. Use glass cleaner or isopropyl alcohol to clean the print surface.
- 10 Children under 10 years old should not use the printer without supervision.
- 11 This machine is equipped with a security protection mechanism. Do not manually move the nozzle or printing platform mechanism manually while booting up, otherwise the device will automatically power off for safety.
- 12 Users should comply with the laws and regulations of the corresponding countries and regions where the equipment is located (used), abide by professional ethics, pay attention to safety obligations, and strictly prohibit the use of our products or equipment for any illegal purposes. Creality will not be responsible for any violators' legal liability under any circumstance.

- 1 请勿尝试任何使用说明中没有描述的方法来使用本机，避免造成意外的人身伤害和财产损失；
- 2 请勿将本机放置在易燃易爆物中或高热源附近，请将本机放置在通风、阴凉、少尘的环境下；
- 3 请勿将打印机放置在振动较大或者其他不稳定的环境下，机器晃动会影响打印机打印质量；
- 4 建议使用厂家推荐耗材，以免造成挤出头堵塞和机器损坏；
- 5 请勿在安装过程中使用其他产品电源线代替，请使用本机附带的电源线，电源插头需接插在带有地线的三孔插座；
- 6 请勿在打印机工作时接触喷嘴以及热床，以防止出现高温烫伤，造成人身伤害；
- 7 请勿在操作机器时佩戴手套或缠绕物，以防可动部件对人身部件造成卷入挤压和切割伤害；
- 8 在打印完毕后及时利用喷头的余温借助工具将喷头上的耗材清理干净，清理时请勿直接用手触摸喷头，以防出现烫伤；
- 9 常做产品维护，定期在断电的情况下，用干布对打印机做机身清洁，拭去灰尘和粘结的打印材料、导轨上的异物；
- 10 年龄在10岁以下的儿童，请勿在没有人员监督的情况下使用本机，以免造成人身伤害；
- 11 本机设有安全保护机制，请勿在开机状态下手动快速移动喷头或打印平台机构，否则设备会自动断电关机保护；
- 12 使用者应遵守设备所在地（使用地）相应国家、地区法律法规，恪守职业道德，注意安全义务，严禁将我司的产品或设备使用在任何非法用途上。如有违反者所应承担的相关法律责任我司概不负责。

Introduction 设备简介	01-01
Parameters 设备参数	02-02
Parts List 零部件清单	03-04
Assemble the 3D Printer 组装3D打印机	05-15
Use the 3D Printer 使用3D打印机	16-21
Start Printing 首次打印	22-24
Maintenance 维修	25-25
Equipment Maintenance 设备保养	26-26
Circuit Wiring 电路接线	27-27
Trouble-shooting 故障检修	28-29

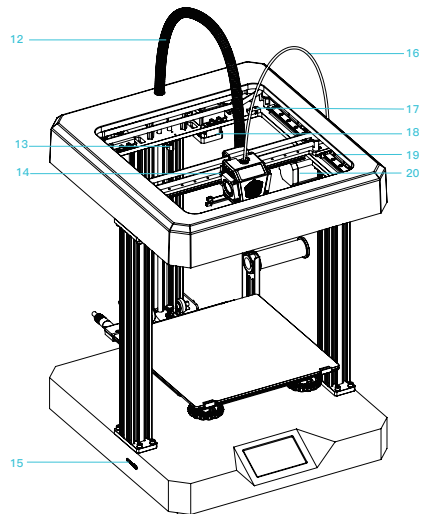
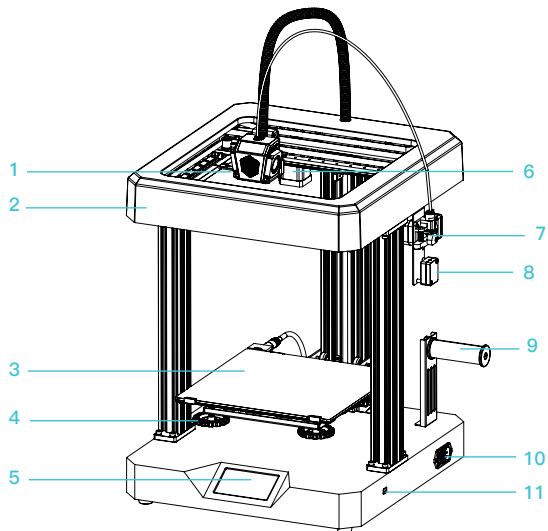

- 1 Nozzle Kit | 喷头套件
- 2 Upper Cover | 上盖
- 3 Printing Platform | 打印平台
- 4 Bed Leveling Nut | 调平螺母
- 5 LCD Screen | LCD显示屏
- 6 X Axis Motor | X轴电机
- 7 Remote Extruder | 远端挤出机

- 8 Filament Detector | 断料检测
- 9 Filament Holder | 料架
- 10 Power Cable Connection | 电源组合开关
- 11 Voltage switching switch | 电压切换拨动开关
- 12 Bellows | 波纹管
- 13 Z Axis Limit Switch | Z轴限位开关
- 14 X Axis Limit Switch | X轴限位开关

- 15 Storage card slot & Type-C interface
存储卡槽&Type-C接口
- 16 Teflon tube | 铁氟龙管
- 17 Y Axis Limit Switch | Y轴限位开关
- 18 Y Axis Motor | Y轴电机
- 19 Sliding rails | 滑轨
- 20 E Axis Motor | E轴电机

Basic Parameters 基本参数

Model 型号	Ender-7
Printing Size 成型尺寸	250*250*300mm
Molding Tech 成型技术	FDM
Nozzle Number 喷头数量	1
Slice Thickness 切片层厚	0.1mm-0.4mm
Nozzle Diameter 喷嘴直径	Standard 0.4mm 标配0.4mm
Precision 打印精度	±0.1mm
Filament 打印材料	1.75mm PLA
File Format 切片支持格式	STL/OBJ/AMF
File Transfer 打印方式	USB/Storage card 联机或存储卡脱机
Slice Software 可兼容切片软件	Creativity Slicer/Cura/Repetier-Host/Simplify3D
Rated Voltage 额定电压	Input 输入:AC115/230V 50/60Hz Output 输出:DC 24V
Rated Power 额定功率	350W
Bed Temp 热床最高温度	≤100°C
Nozzle Temp 喷嘴最高温度	≤260°C
Resume Printing 断电续打	Yes 支持
Filament Detector 断料检测	Yes 支持
Language 语言	中文/ English/ Español/ Deutsche/ Français/ Русский/ Português/ Italiano/ Türk
Operating System 电脑操作系统	Windows XP/7/8/10 MAC/Linux
Printing Speed 打印速度	≤250mm/s

3. Parts List 零件清单

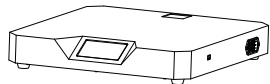

1 Base Frame x 1
底座

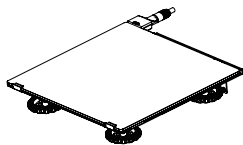

2 Printing Platform x 1
打印平台

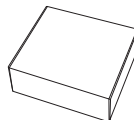

3 Tool Box x 1
工具包



4 Filament x 1
耗材



5 Z-axis Component
Z轴组件

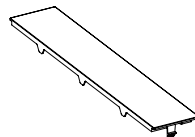

6 Z-axis Cover
Z轴盖板

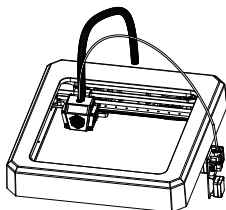

7 Top component
顶部组件



8 Filament Holder
料架

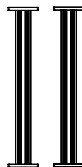

9 Z-axis profile
Z轴型材



Tool list 工具包清单



10 Spool & Nuts x 1
料管及料管螺母



11 Hex keys, Wrench x 1
& Screwdriver
扳手和螺丝刀



12 Socket Spanner x 1
套筒扳手



13 M4*6 cup head x 12
screw
M4*6圆柱头螺钉

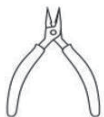

14 Diagonal Pliers x 1
剪钳



15 M4*10 Hexagon flat round
head screw x2
内六角平圆头螺丝M4*10



16 Nozzle Cleaner x 1
通针



17 Storage Card & x 1
Card Reader
存储卡和读卡器



18 Spare Blue clip x 2
备用蓝色线夹



19 Spade x 1
铲刀



20 Nozzle x 2
喷嘴



21 Cable Ties x 1
扎带



22 M5*18 Sems Screw x 24
M5*18组合螺丝



23 Cable connectors x 3
排线压扣



24 Serrated lock washers x 2
外锯齿垫圈



25 Power cord x 1
电源线

Tips: the above accessories are for reference only, in kind prevail! 注意:以上配件仅供参考,请以实物为准!

4. Install Profile 安装型材

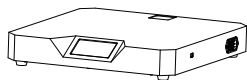

1 Base Frame x 1
底座



5 Z-axis component
Z轴组件



22 M5*18 Sems Screw x 4
M5*18组合螺丝



24 Serrated lock washers x 1
外锯齿轮垫圈

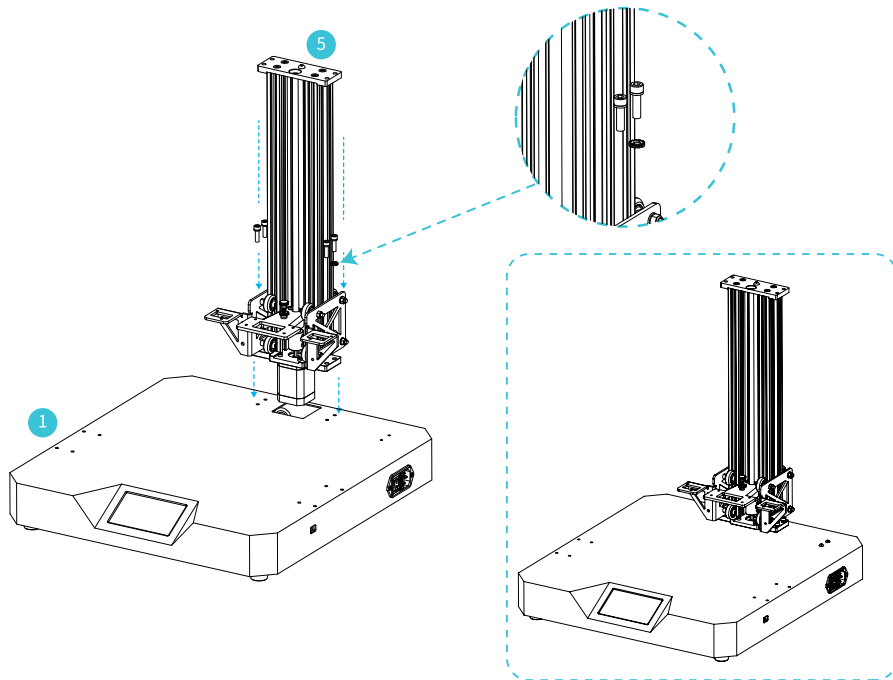

4. Install Profile 安装型材

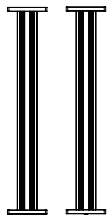

9 Z-axis profile
Z轴型材



22 M5*18 Sems Screw x 8
M5*18组合螺丝

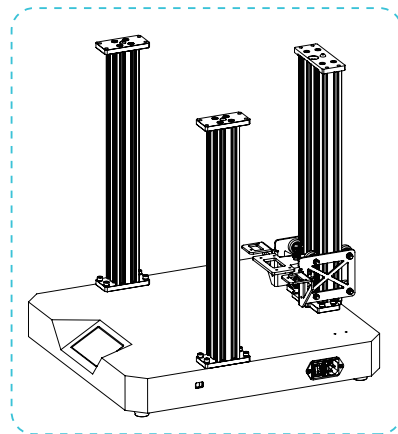
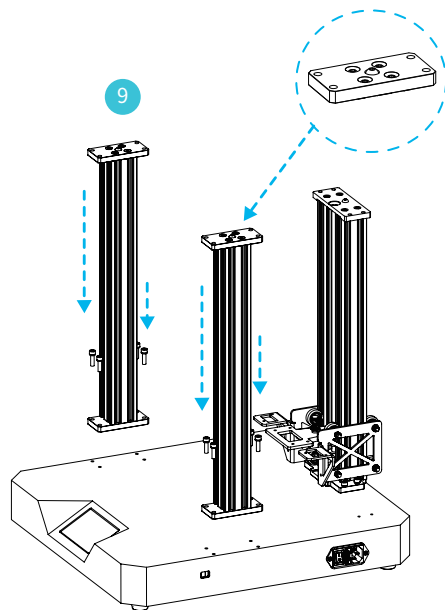

5. Install the Printing Platform 安装打印平台

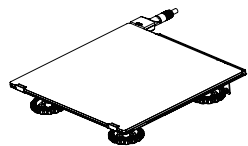

2 Printing Platform × 1
打印平台



13 M4*6 cup head × 8
screw
M4*6圆柱头螺钉

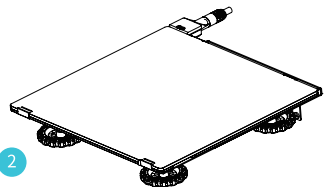

2

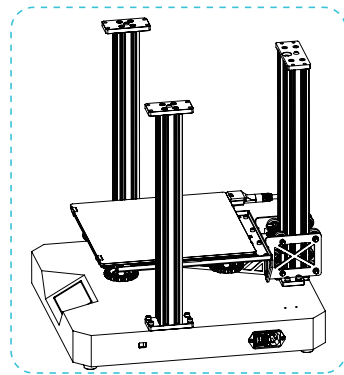
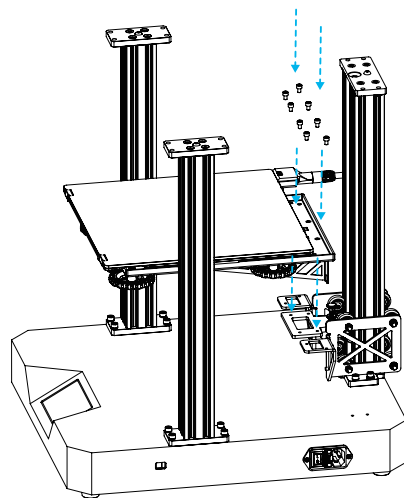

5. Install the Printing Platform 安装打印平台



- 13 M4*6 cup head x4
screw
M4*6圆柱头螺钉

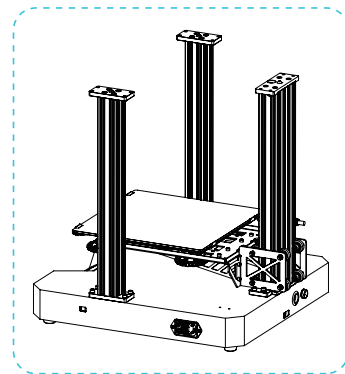
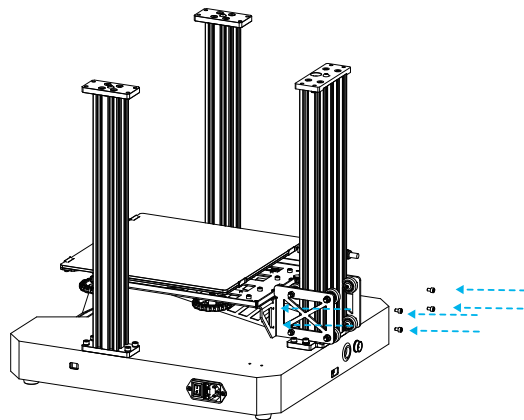

6. Install Top Component 安装顶部组件

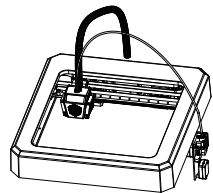

- 7 Top component
顶部组件



- 22 M5*18 Sems Screw x 4
M5*18组合螺丝



- 24 Serrated lock washers x 1
外锯齿垫圈

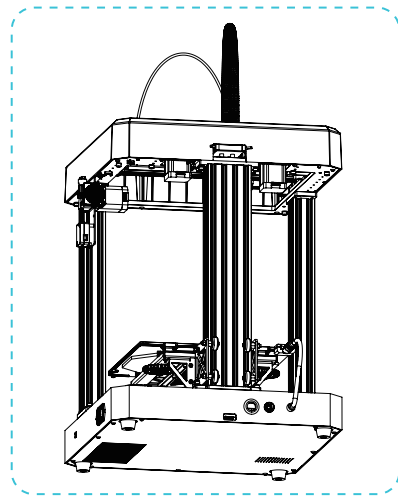
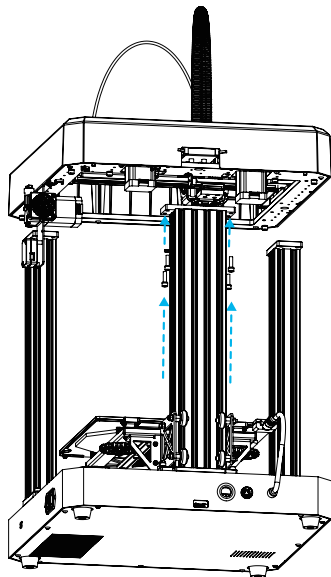

6. Install Top Component 安装顶部组件



22 M5*18 Sems Screw x 8
M5*18组合螺丝

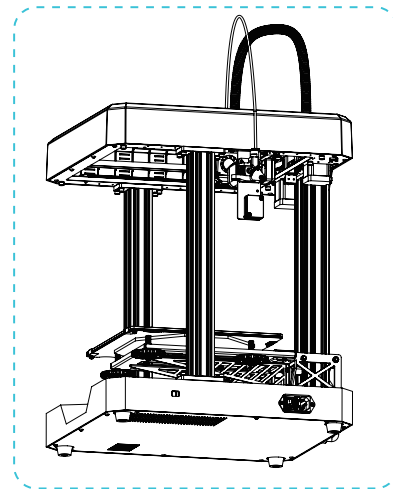
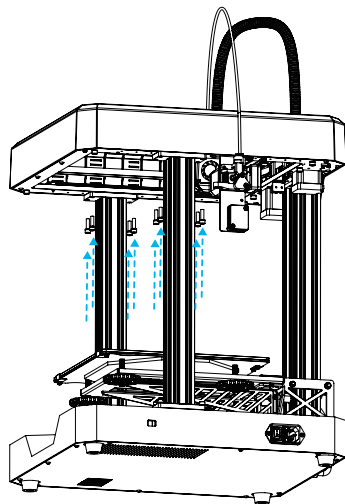

7. Install Filament Holder 安装料架

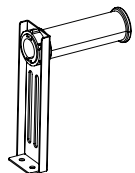

8 Filament Holder
料架



15 M4*10 Hexagon flat round
head screw x2
内六角平圆头螺丝M4*10

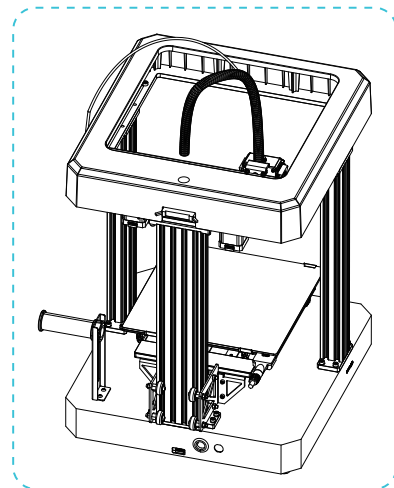
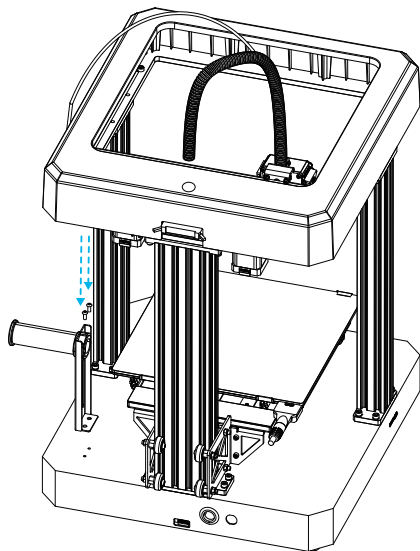

8. Install Z-axis Cover 安装Z轴盖板

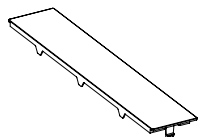

6 Z-axis Cover
Z轴盖板

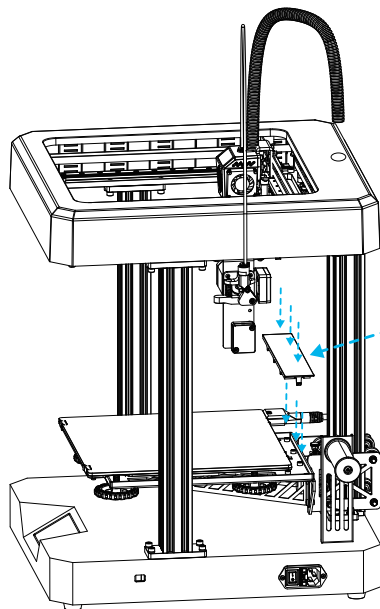

Snap into place in the direction shown in the figure.
按图示方向卡入

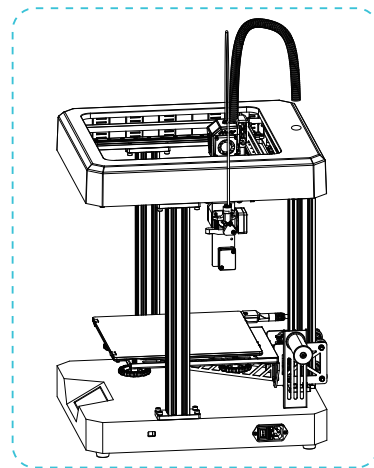
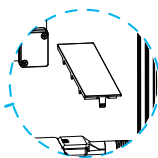



23 Cable connectors x 3
排线压扣×3

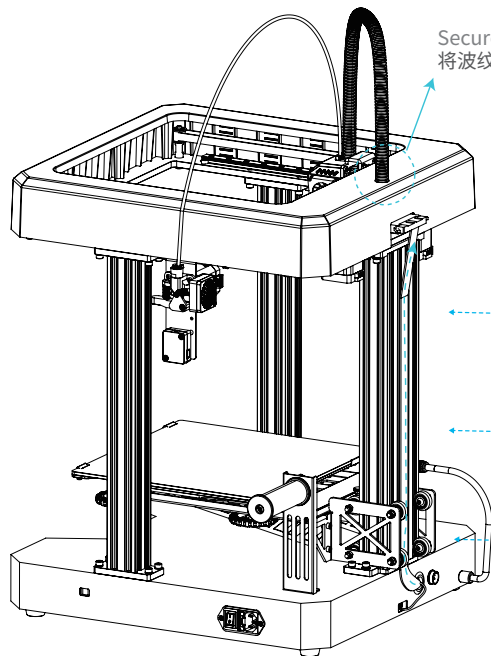

Securely insert the bellow into the mounting hole.
将波纹管用力插入安装孔

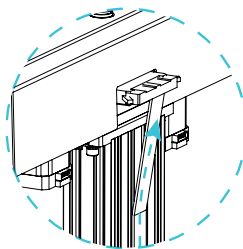

Put the cable plug into the socket
将排线插头装入插座中

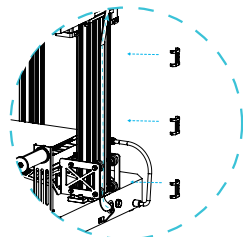

Install the cable connectors
安装排线压扣

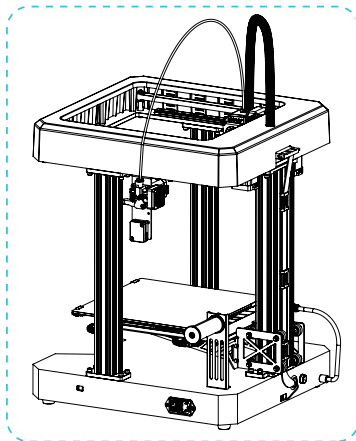

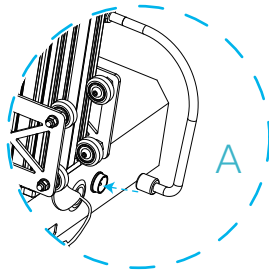
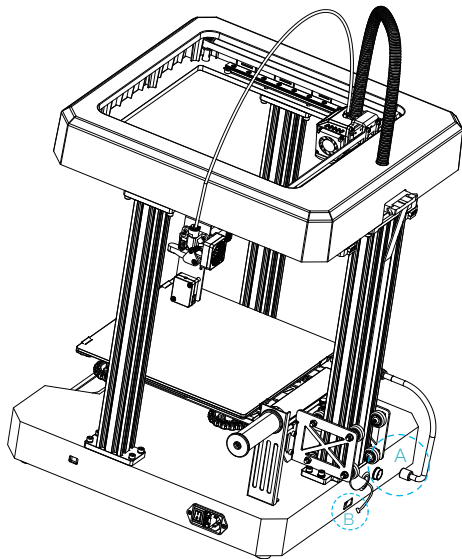

Connect the heated bed cable.
连接热床线

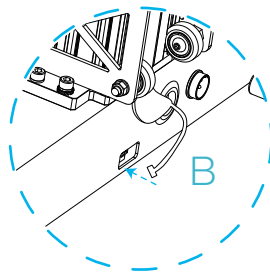

Connect the Z-axis motor cable.
连接Z轴电机线



Note: Align the male plug with the female plug and insert.
注意：公头凸起处对准母头凹起处插入

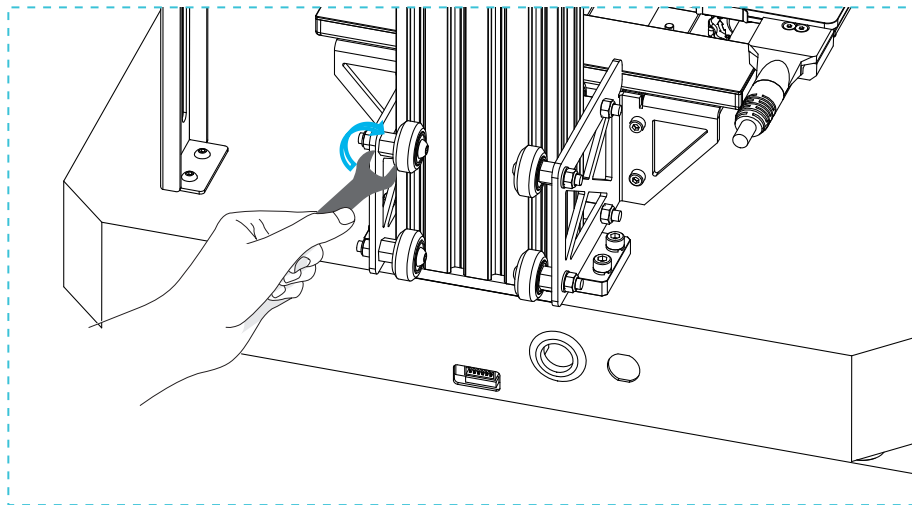

Gently dial the V-wheel manually to check whether it is idling. If idling happens, please use an open-ended wrench to adjust the off-center separation pillar according to the illustrated direction, so that the V wheel is not idling.

用手轻拨V轮，检查其是否有空转，如有此现象请使用开口扳手按图示方向调节偏心隔离柱，使V轮无空转。

Click back to the origin in the interface after power-on, and then go on moving the Z axis independently. Put your hand on the printing platform to observe whether the platform is stuck. If it is, please adjust the off-center separation pillar in the opposite direction according to the illustrated direction to make the V-wheel move smoothly.

通电在界面点击回原点，回原点后单独移动Z轴。将手放在打印平台上，观察平台是否有卡顿现象，如有卡顿按图示方向的反方向调节偏心隔离柱使其运动顺畅。

11. Bed Leveling 调平平台

Choose setting-leveling- Aid- leveling,clicking number ①/②/③/④
选择设置→调平模式→辅助调平，点击数字①/②/③/④。

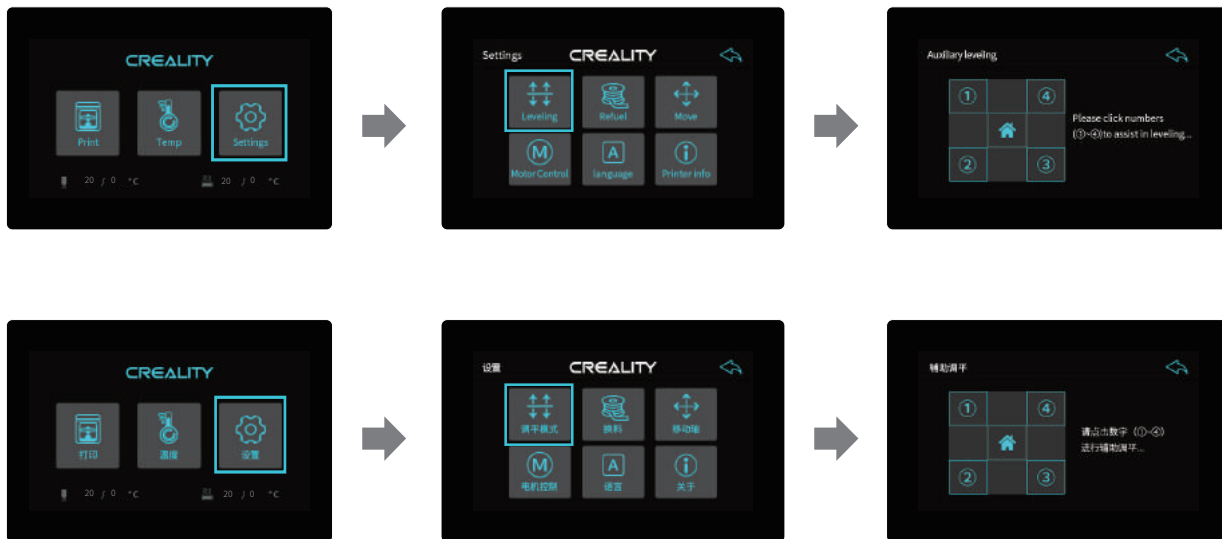

Note: The UI information is only for reference, the actual UI may be different.
注意：界面仅供参考，实际以UI为准。

11. Bed Leveling 调平平台

Move the nozzle the front/left leveling screw and adjust the platform height by turning the knob underneath (The thickness of a piece of A4 paper).

移动喷嘴至调平螺母上方附近。拧动螺母，调节打印平台，使其与喷嘴处于刚好贴合状态，间距约为0.1mm（一张A4纸的厚度）。按顺序调平四个角。

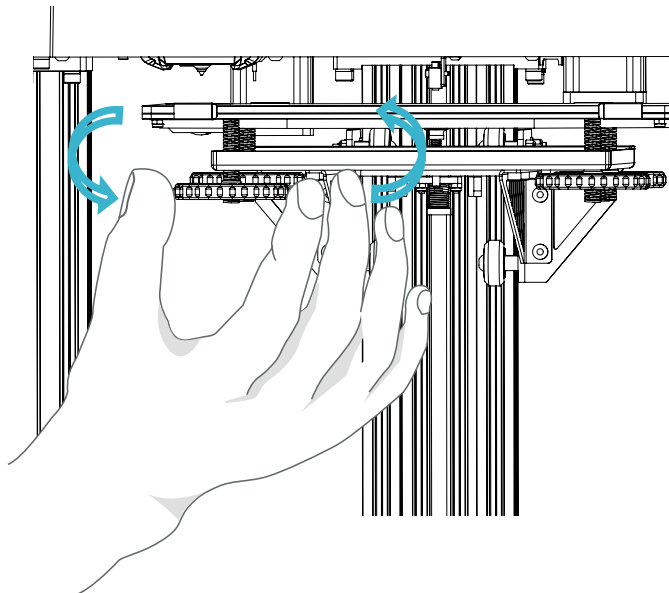

⚠

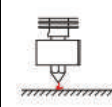
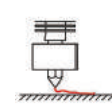
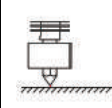
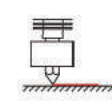
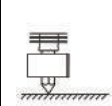
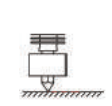
		⊗
<p>The nozzle is too far away from the platform, so the consumables can not adhere to the platform. 喷嘴离平台太远，耗材无法粘附在平台上。</p>		
		✔
<p>Filament are extruded evenly, just sticking on the platform. 耗材挤出均匀，刚好贴在平台上。</p>		
		⚠
<p>The nozzle is too close to the platform, and the filament are not extruded enough, even scraping the platform. 喷嘴离平台太近，耗材挤出不足，甚至刮坏平台。</p>		

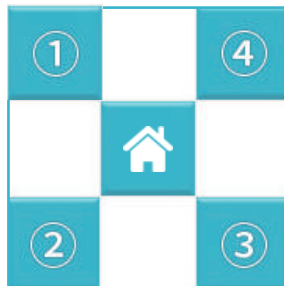

11. Bed Leveling 调平平台

Use a piece of A4 paper (standard printer paper) to assist with the adjustment, making sure that the nozzle lightly scratches the paper. Complete the adjustment of the screw on all 4 corners. Repeat above steps 1-2 times if necessary. Keep adjusting until there is slight resistance on the A4 paper from the nozzle.

我们可以利用一张A4纸辅助调平,使喷嘴刚好能在A4纸上产生划痕。依次完成四个边上调平螺母的调节。不断调整直到在拉动A4纸时能感受到来自喷嘴的轻微阻力。

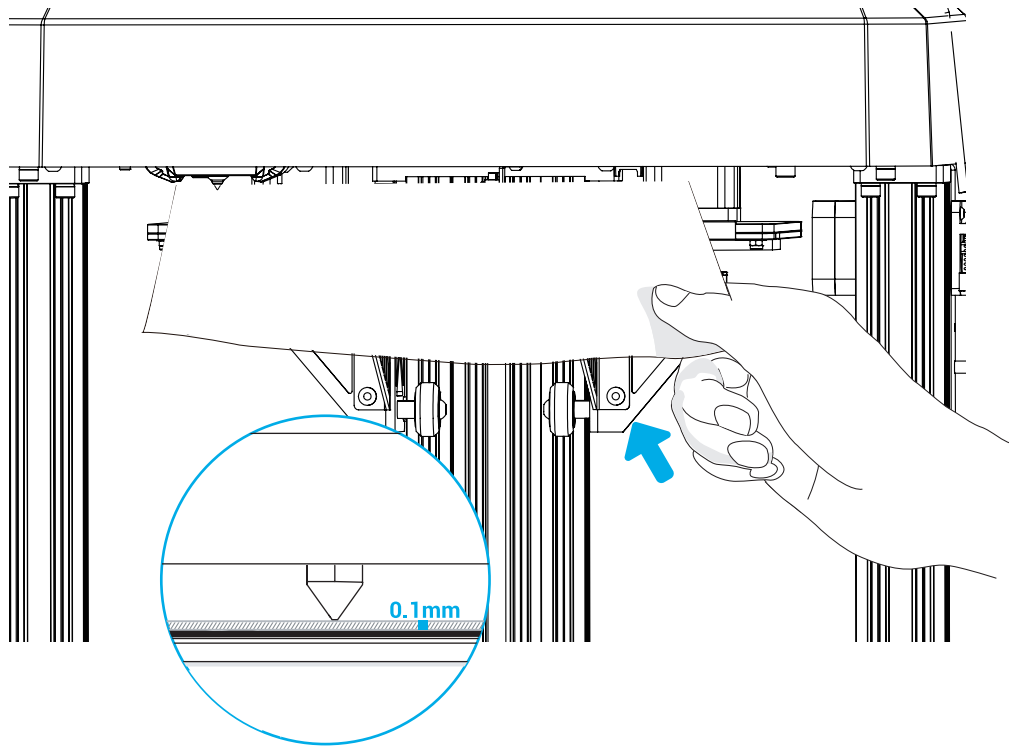

12. Preheating 预热

Method 1

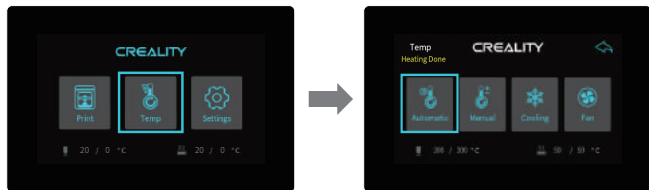

方法1



Method 2

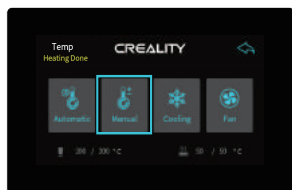

方法2

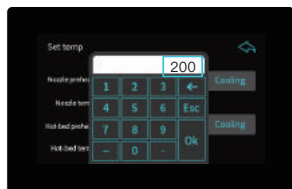
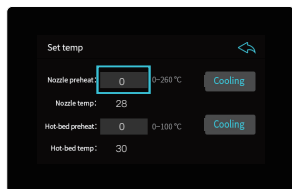

13. Load Filament 装料

When you wait for the temperature to rise, hang the filament over the Filament Holder.

当您等待温度上升时,把耗材挂在料架上。



4 Filament x 1
耗材

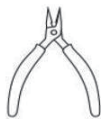

14 Diagonal Pliers x 1
剪钳

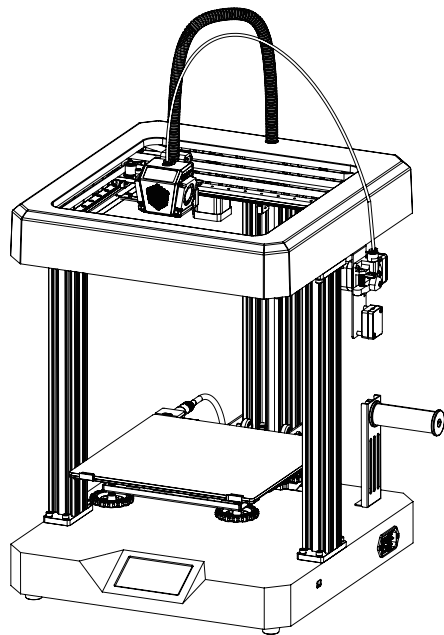

For smoother Load Filament, the end of the filament should be placed as shown below.

为了顺利完成装料,耗材的末端位置应如图所示。

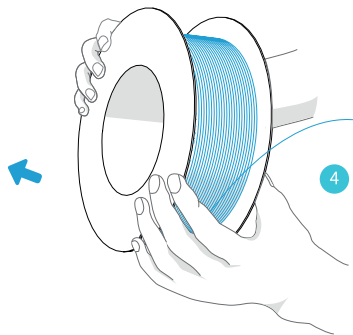
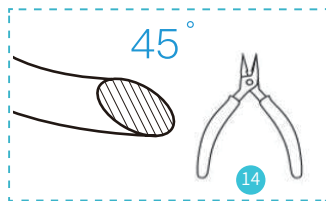

13. Load Filament 装料

When the current temperature reaches the target temperature, pass the consumables through the material detection test, insert the extruder holes into the nozzle position, and wait for the consumables to flow out of the nozzles .

当前温度达到目标温度时，将耗材通过断料检测，插入挤出机小孔直至喷嘴位置，等看到喷嘴处有耗材流出即表示耗材已经装载完成。

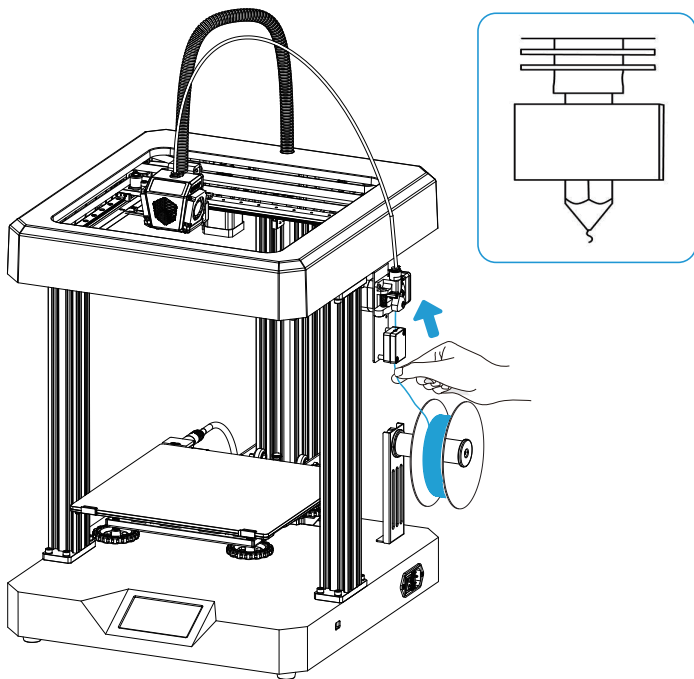

Tips: How to Replace the Filament?

Method 1:

Insert the new filament into filament runout detection module, the indicator light is on. Click the "Resume after filament runout" in the display, and set the nozzle temperature to 200°C. Take out the remaining filament in the filament runout detection module from the lower part of the extruder after the temperature rises. Push the extruding clamp until the filament is sent into the nozzle through the filament runout detection module.

Method 2:

Insert the new filament into filament runout detection module, the indicator light is on, then click the "Resume after filament runout" in the display. When it starts to print, hold the filament and allow it to go through the extruder. (The filament may not be properly fed into the Teflon tube due to bending or other reasons, resulting in failure of resumption).

Tips: 如何更换耗材?

方法1:

将新耗材插入断料检测内，指示灯亮，点击显示屏中的断料续打，将喷嘴温度设置到200°C，然后将断料检测内的上批剩余的耗材从挤出机下方取出，温度升高后拉出剩余耗材。按压挤出夹，将通过断料检测的耗材送入喷嘴为止。

方法2:

将新耗材插入断料检测内，指示灯亮，点击显示屏中的断料续打，开始续打后用手拿着耗材，将其随着打印顺过挤出机。(该方法有存在由于耗材弯曲等原因，不能正常送入铁氟龙管内，造成续打连不上风险)

14. Start Printing 开始打印

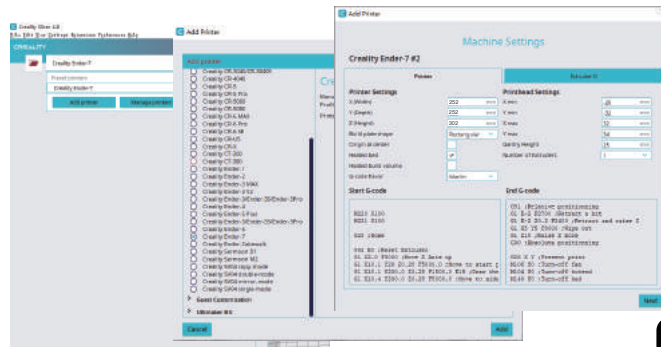

3. Select language→Next→Select your machine→Next→Finish.



1. Double click to install the software. | 安装软件
2. Double click to open the software. | 打开软件

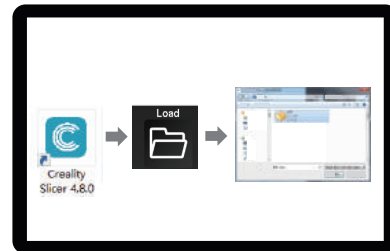

4. Open Creativity 3D slicer → Load (Read file) → Select file.
打开创想三维切片软件→Load (读取文件) → 选择文件。



3. 依次选择语言→Next→选择对应机型→Next→Finish, 完成设置.

14. Start Printing 开始打印



This machine can print at a fast speed, but it is recommended to print at normal speed! Notes: the temperature of the nozzle is set according to the printing speed. Take PLA as an example:

本机器支持高速打印,但建议以正常速度打印!注意:不同速率时,喷嘴打印温度需相应调整设置,创想配送PLA推荐设置参数:

Cutting speed 切片速度	60mm/s	125mm/s	250mm/s
Nozzle temperature 喷嘴温度	Around 200°C 200°C左右	Around 210°C 210°C左右	Around 220°C 220°C左右

The printing temperature is different owing to the variety of PLA filaments. Please refer to the actual situation.

打印温度会存在些许差异,请根据实际打印情况适当调整。

14. Start Printing 开始打印

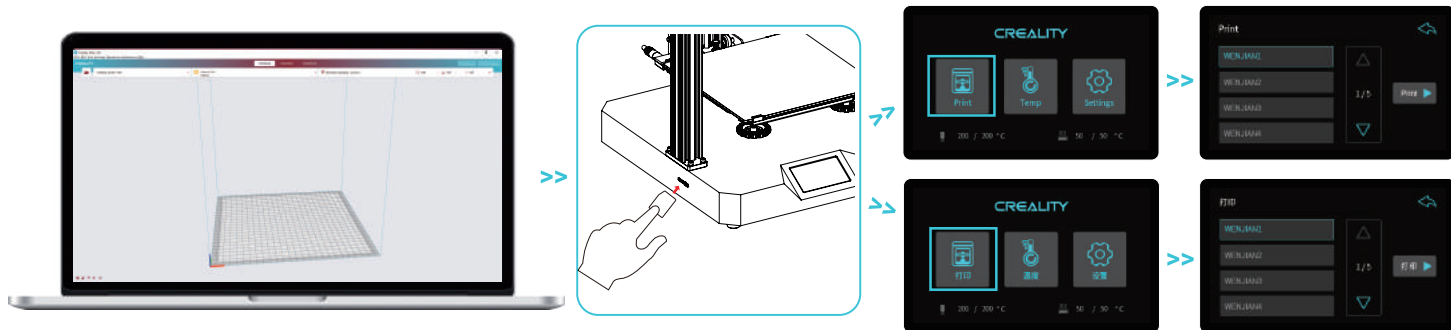

5. Generate G-code, and save the gcode file to storage card.
生成 G 代码→保存到存储卡

6. Insert the storage card→ Print → Select the file to be printed.
插入存储卡→点击打印控件→选择要打印的文件



File names must be Latin letters or numbers, not Chinese characters or other special symbols
文件名需为拉丁字母或数字, 不能为汉字或其他特殊符号



Notes: For details on the software instructions, please refer to the slicing software manual in the storage card!
温馨提示: 软件使用说明详情, 请见存储卡内切片软件使用手册!



Warning: Please don't insert or remove the storage card during printing.
警告: 在打印过程中, 禁止插拔存储卡。

15.Maintenance- disassemble the upper cover 维修—拆上盖



First move the nozzle unit to where close to the origin .

先将喷头组件移至原点附件。

Diagram 1: Remove the screws used for fixing of top cover,

图1:将固定上盖的螺丝拆下;

Diagram 2: Press the position indicated by red arrow from the inside,

图2:从内部按压红色箭头处,

open the buckles on both sides of the top cover and move them upward simultaneously

将上盖左右两侧卡扣打开并同时向上移,

disengage the buckles, and the top cover is removed.

使卡扣脱离,即完成拆上盖操作。

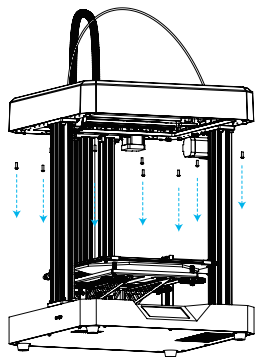

Diagram 1

图1

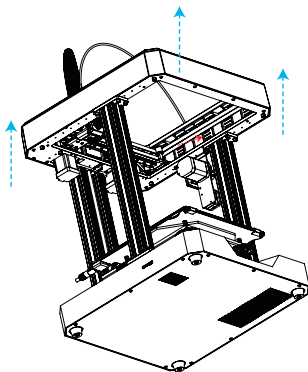

Diagram 2

图2

Diagram 1: Move the nozzle unit to where close to the origin first before assembly.

图1:安装时先将喷头组件移至原点附件。

Diagram 2: Then align the positioning pins of the upper cover with the holes of the mounting plate.

图2:然后将上盖的定位销与安装板孔位对齐。

Press the upper cover down again, and then lock the removed screws to the corresponding positions.

再向下扣压上盖,之后将拆下的螺丝锁在相应的位置上。

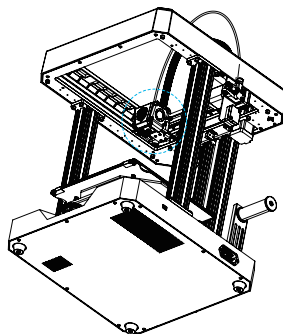

Diagram 1

图1

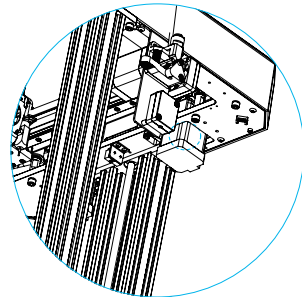
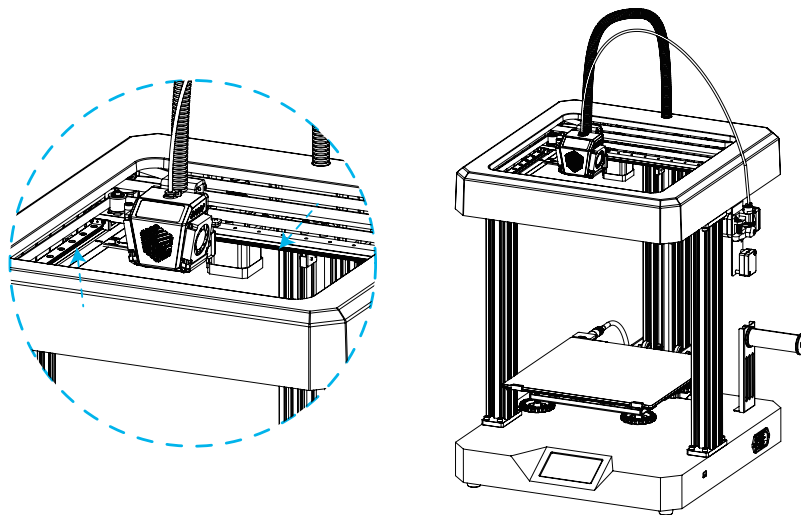

Diagram 2

图2



Maintenance of sliding rails/ sliding blocks:

Three sliding rails and sliding blocks in the X/Y line should be periodically maintained (generally per 3-6 months).

When surfaces of sliding rails lack the lubricant or there is abnormal sound during the operation, it means that balls in sliding blocks lack the lubricant and lubricating grease or lubricating fluid should be applied on the sliding rails.

滑轨/滑块保养：

X/Y轴三个滑轨和滑块需定期保养（一般为3-6个月），当滑轨表面缺润滑剂或者运动有异响时，表明滑块内滚珠缺润滑剂，需在滑轨上涂润滑脂或润滑油。

17. Circuit Wiring 电路接线

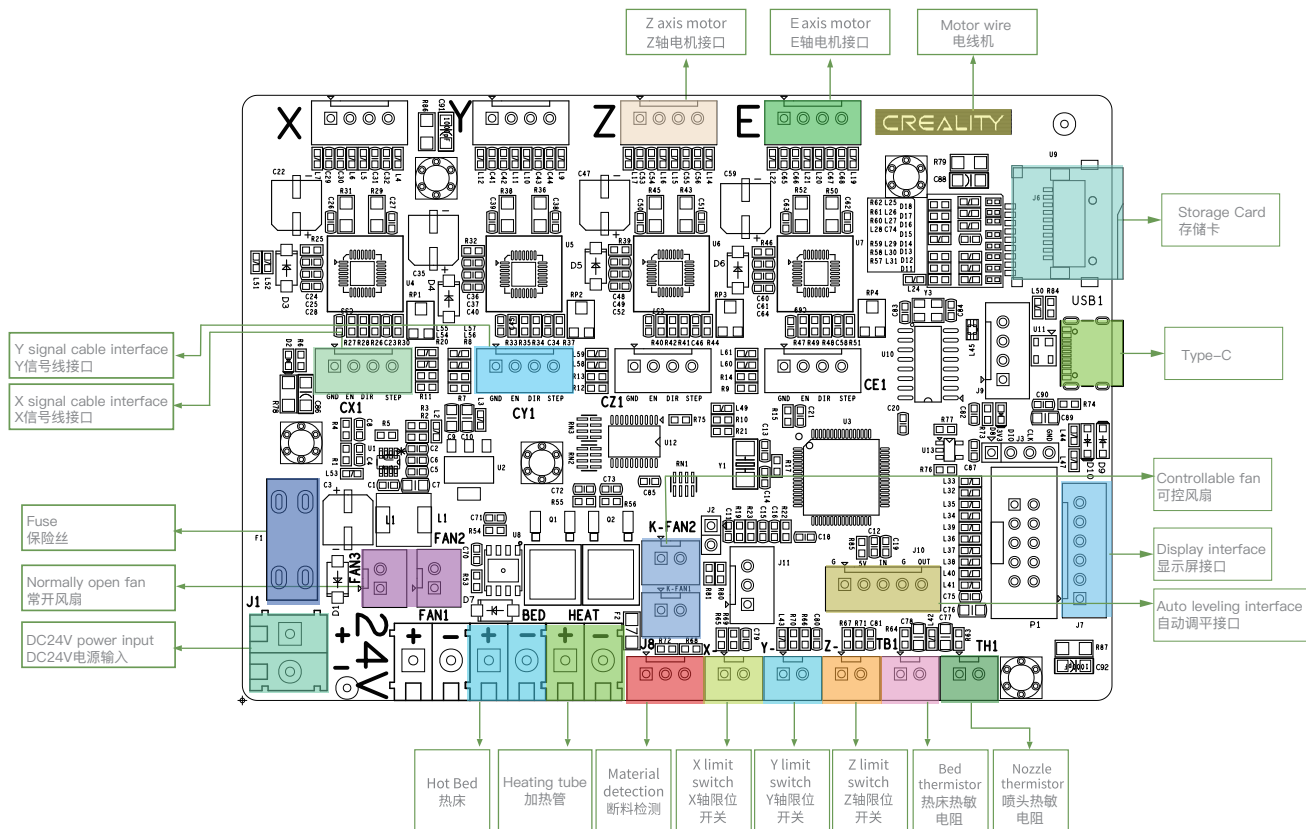

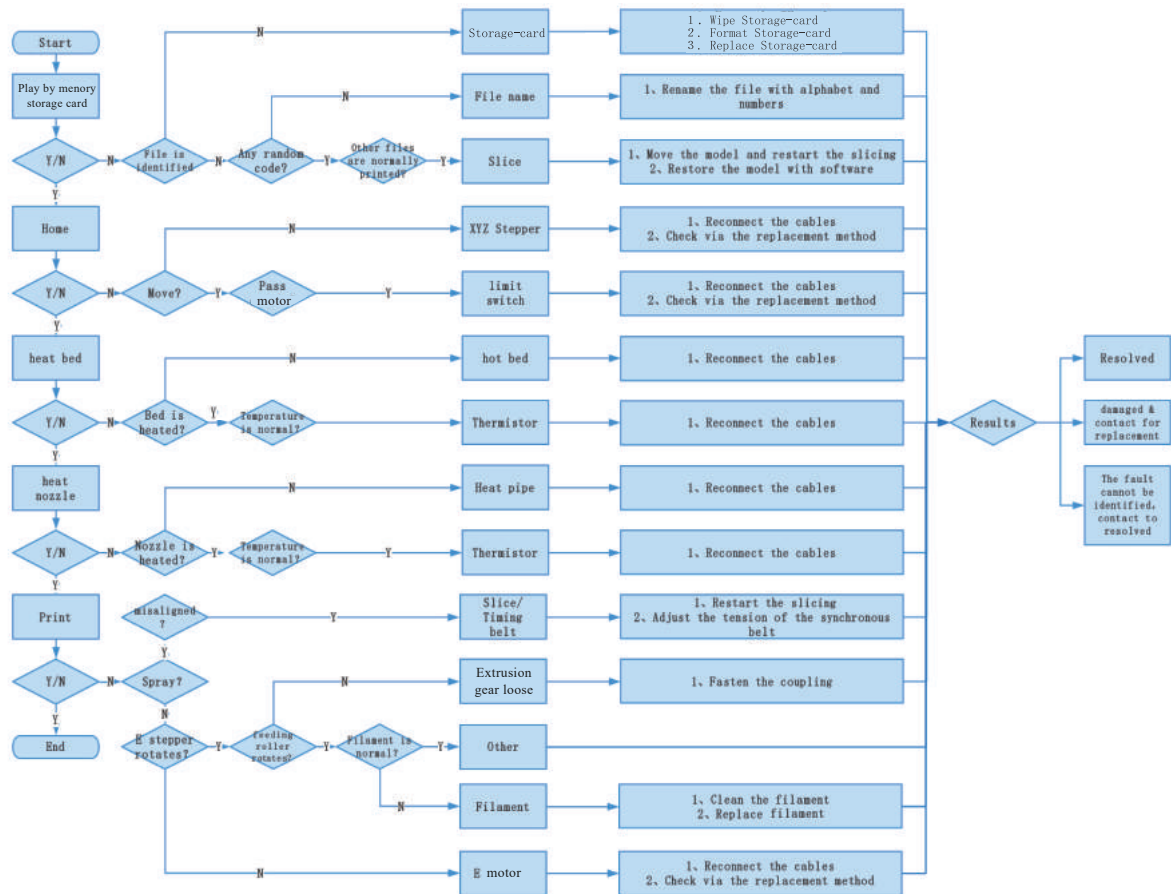

18. 故障检修

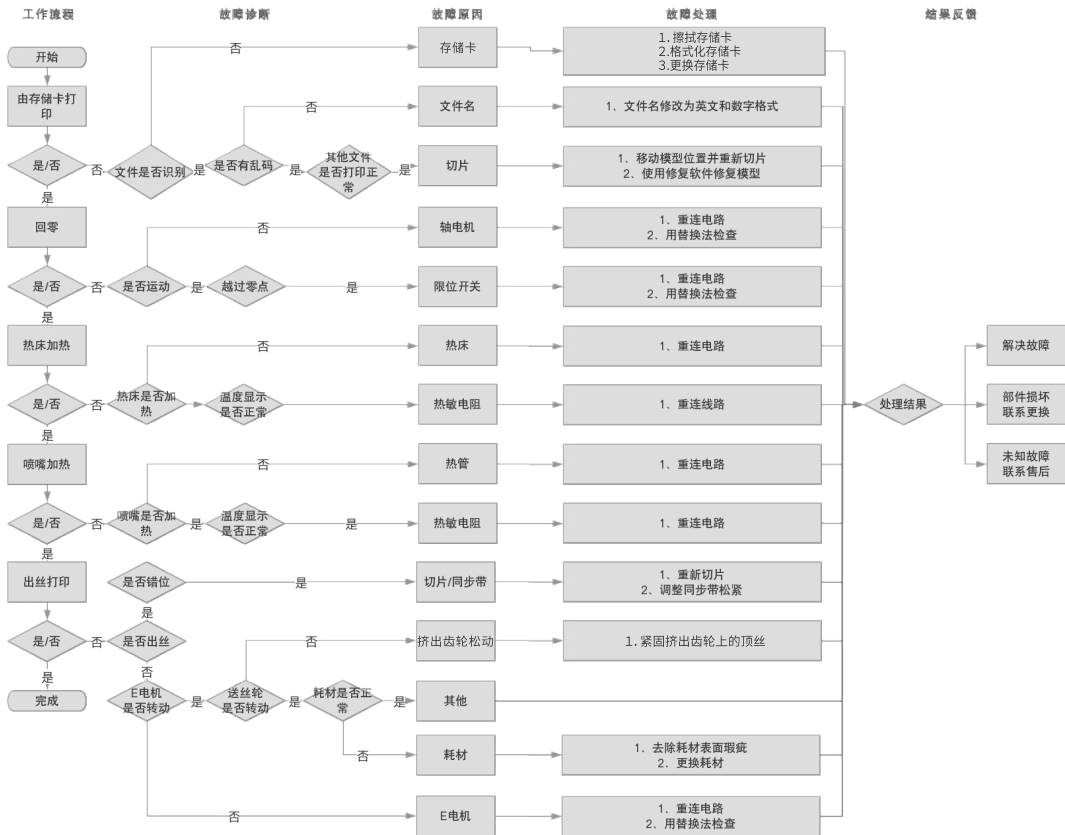

Due to the differences between different machine models, the physical objects and the final images can differ. The final explanation rights shall be reserved by Shenzhen Crealty 3D Technology Co., Ltd.

因每款机型不同,实物与图可能有所差异, 请以实物为准, 最终解释归深圳市创想三维科技有限公司所有。



Scan To Learn More
扫码了解更多

SHENZHEN CREALTY 3D TECHNOLOGY CO., LTD.

Add: 18F, JinXiuHongDu Building, Meilong Blvd., Longhua Dist.,

Shenzhen, China 518131

Official Website: www.crealty.com

Tel: +86 755-8523 4565

E-mail: info@creality.com cs@creality.com

深圳市创想三维科技有限公司

深圳市龙华区民治街道新牛社区梅龙大道锦绣鸿都大厦18F

公司网站: www.cxsw3d.com

服务热线: 400 6133 882 0755-8523 4565

